

*wattbike*

ATOMX

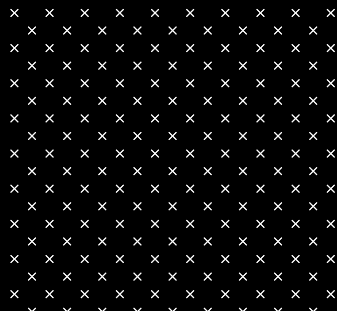

QUICK START GUIDE

WELCOME TO  
THE TRIBE

#WATTBIKERS

## WELCOME TO YOUR WATTBIKE ATOMX

THE INDUSTRY'S MOST  
ADVANCED SMART BIKE

This guide will show  
you how to build and  
set up your AtomX,  
how to connect to  
your preferred devices  
and how to get the  
most from your  
AtomX's features.

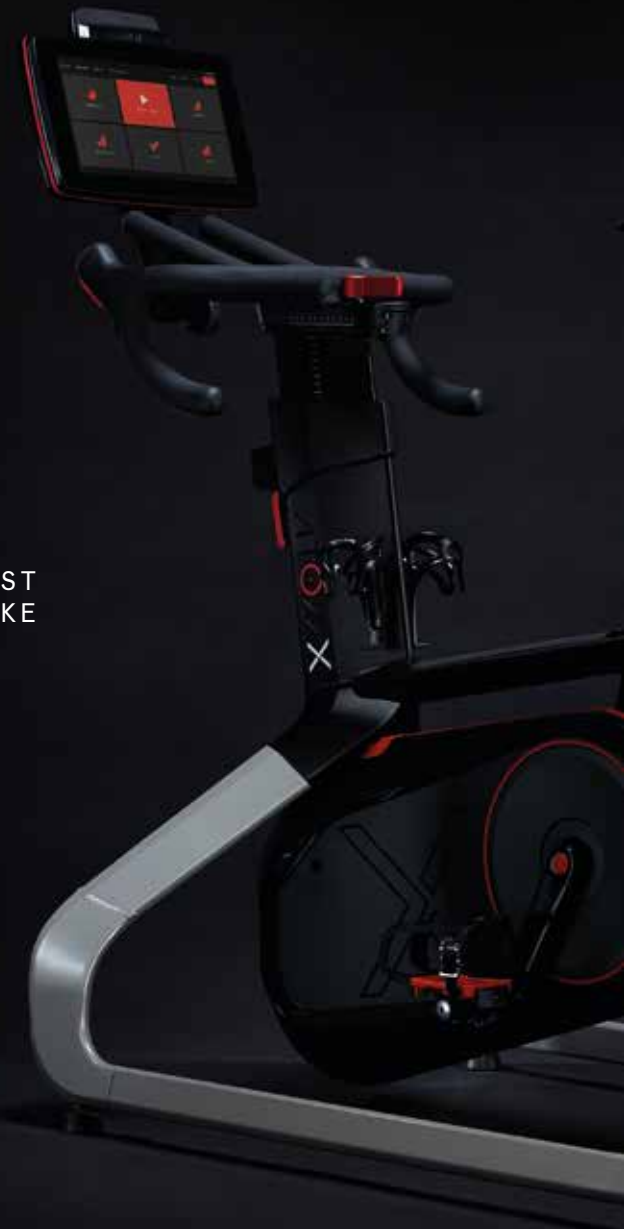

## 01 IN THE BOX

- Wattbike AtomX
- Wattbike Performance Touchscreen
- Power Adaptor
- Combination Pedals
- Quick Start Guide
- Allen Keys
- Spanner

## 02 SPECIFICATION

BIKE WEIGHT	48kg
BIKE FOOTPRINT	Floor space = 100 x 68cm Footprint inc Touchscreen = 144 x 68cm
MAX RIDER WEIGHT	150kg (23st, 81b)
MIN - MAX RIDER HEIGHT	152cm - 198cm (5' - 6'5")
RESISTANCE TYPE	Electromagnet
POWER RANGE	0 - 2500W
PEDALS	Combination pedals fitted as standard
WIRELESS TECHNOLOGIES	Wi-Fi, Bluetooth, NFC, ANT (Heart Rate Only), ANT+, Polar (Heart Rate Only) ANT+ FE-C, Bluetooth FTMS
COMPATIBLE HR DEVICES	BLE, ANT+, ANT (Suunto), Polar
SHIFTERS	Each 3 buttons, hard-wired fully integrated digital shifters with vibration motor
GEARS	22 virtual
GRADIENT	0 - 25%
POWER REQUIREMENTS	Mains powered 12V 7A



# 03 FEATURES

WATTBIKE PERFORMANCE TOUCHSCREEN, WI-FI, BLUETOOTH, FTMS, ANT+, FE-C, NFC AND ANT COMPATIBILITY

PERFORMANCE TOUCHSCREEN ANGLE ADJUSTMENT

DUAL THREE BUTTON DIGITAL SHIFTERS, HARDWIRED AND INCORPORATING VIBRATION MOTOR

HORIZONTAL HANDLEBAR ADJUSTMENT

ADJUSTABLE HANDLEBAR HEIGHT

2X BOTTLE CAGE

ELECTROMAGNETIC RESISTANCE

TRANSPORTATION ROLLERS

HORIZONTAL SADDLE ADJUSTMENT

ADJUSTABLE SADDLE HEIGHT

POWER ACCURACY +/-1%

COMBINATION PEDALS

POWER INLET

LEVELLING FEET

## 04 GET READY TO RIDE

If you have ordered your bike as a boxed delivery, please follow the below instructions carefully to ensure safe use following the build.

### BUILD

- 1 Open the box and remove all contents and parts, placing these to one side. Use a knife to cut the side of the box open. Remove the handlebar by cutting the tie wraps on the side.



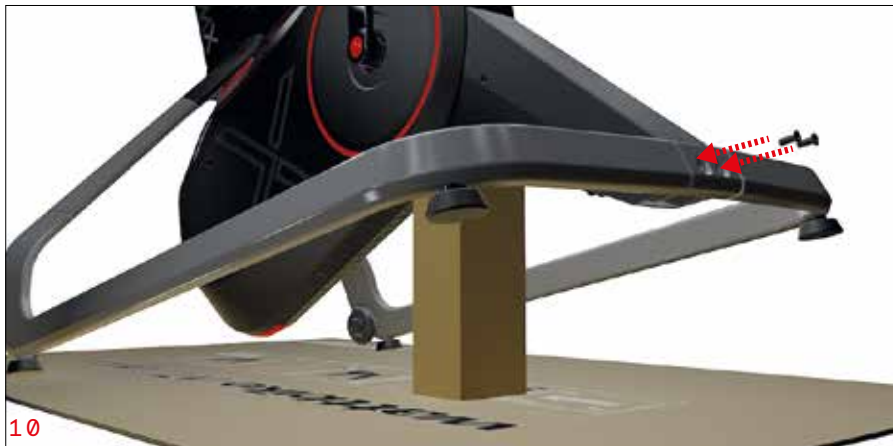
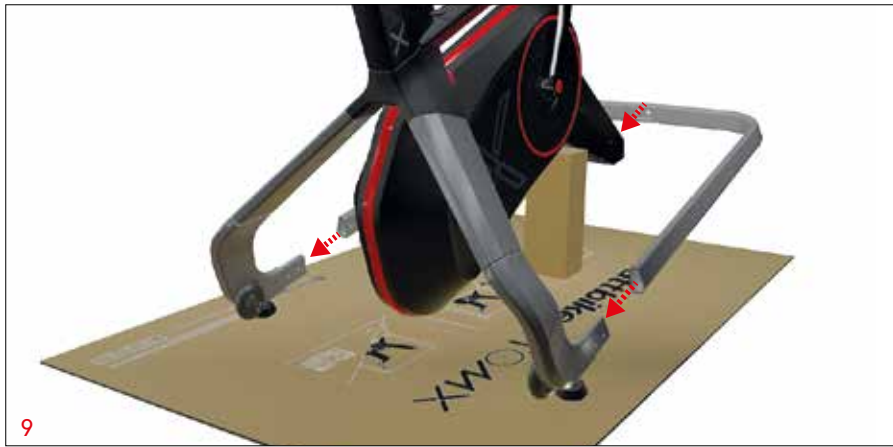



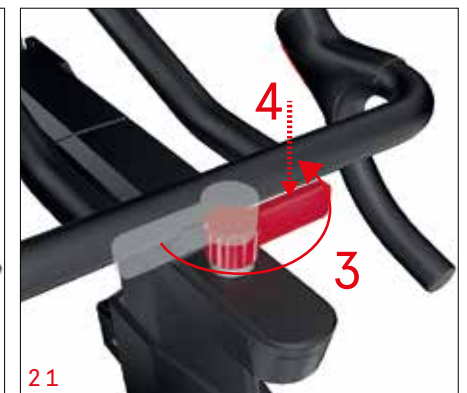
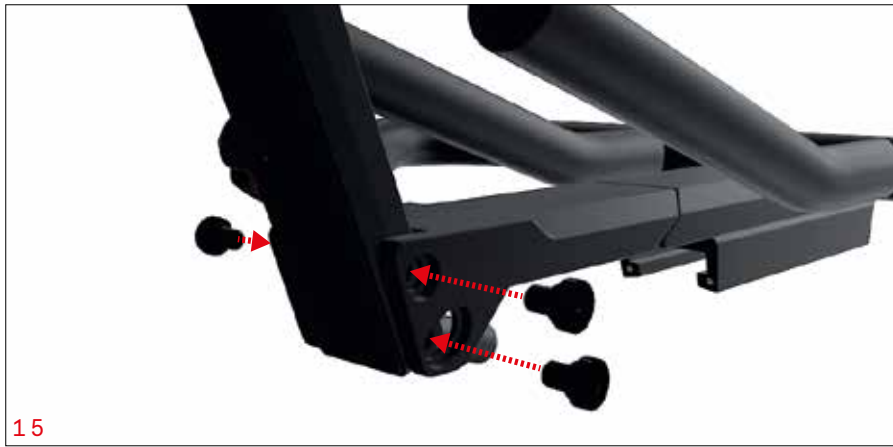

REPEAT STEPS 20-21 UNTIL TIGHT

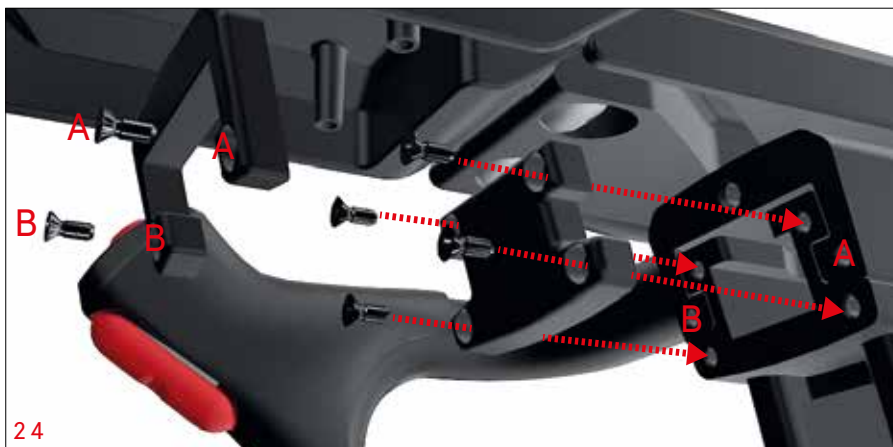
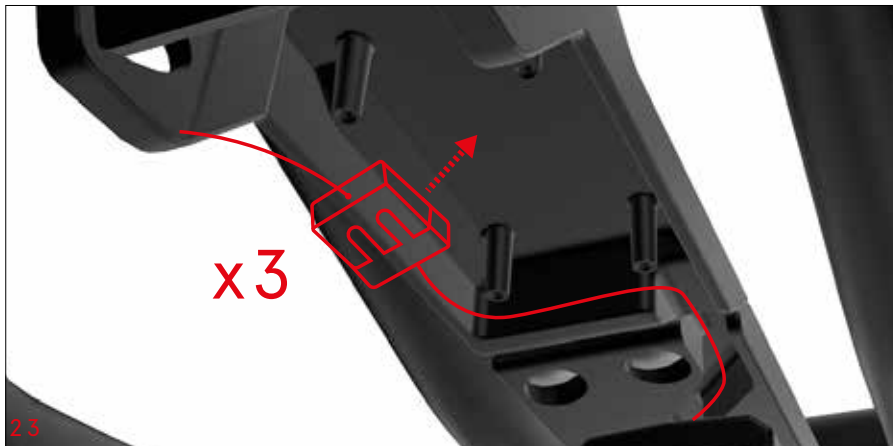
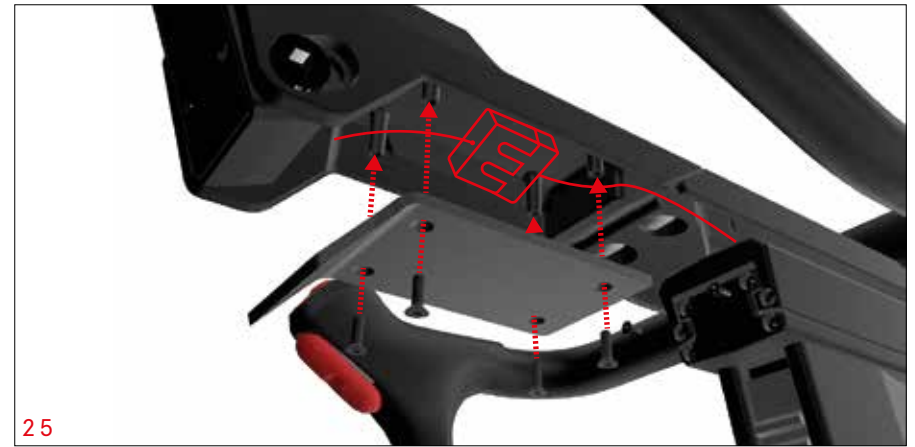



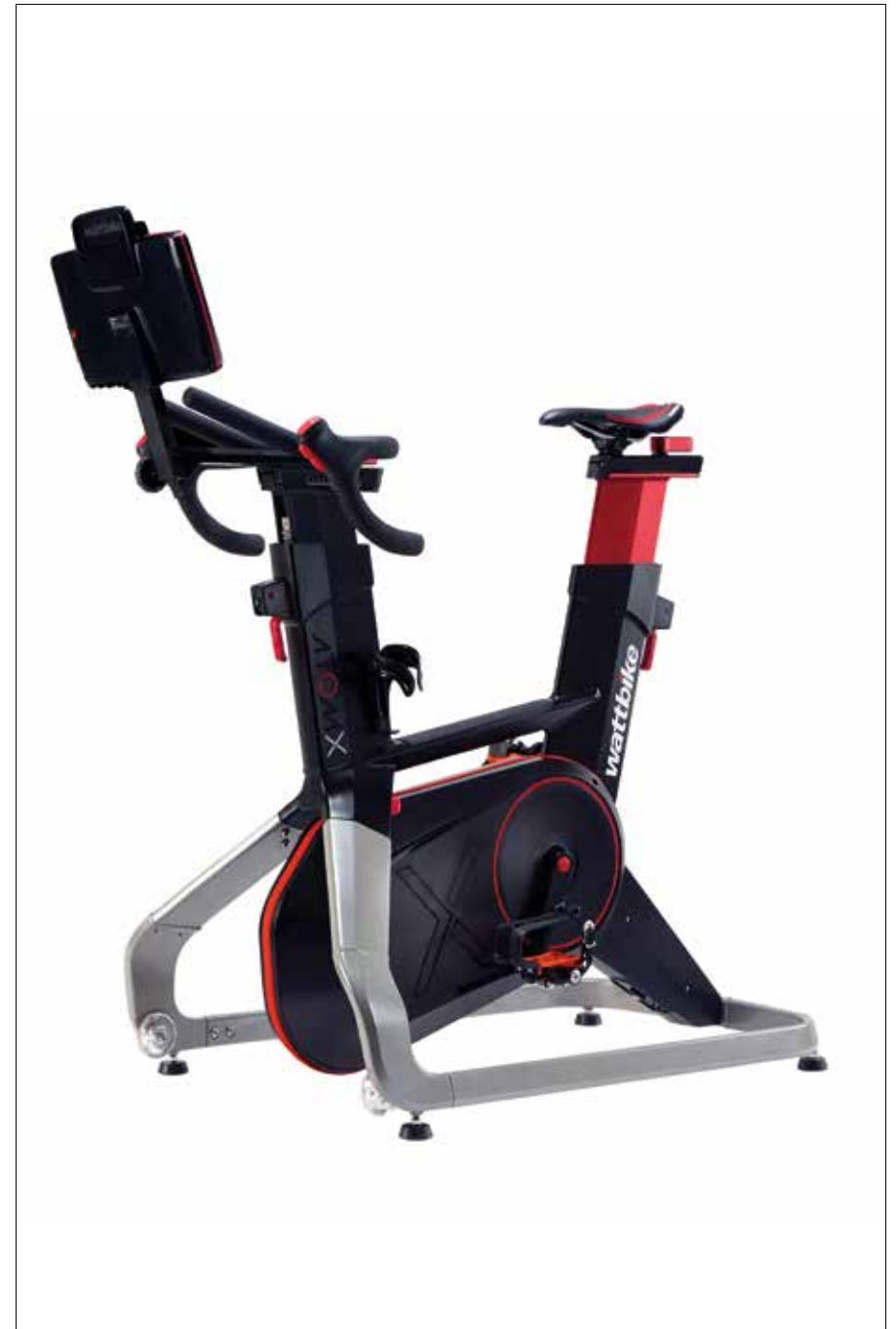



## ADJUSTING LOCK LEVERS

When adjusting the lock levers for the saddle or the handlebars, it is imperative that after adjustments have been made, the lock lever is returned to the **fully locked position** (FIG 4). If the lever is left unlocked (FIG 3), it is at risk of allowing the saddle or handlebar to slide down during use.



## RESISTANCE MODES

You have the ability to change between two resistance modes during a session.

**Gear mode:** This is the default mode on your AtomX. Use the up and down buttons to change your gear. This mode is most like riding a bike.

**Ergo mode:** In this mode, the AtomX will hold you to a target wattage, regardless of your cadence.

To switch between the modes, press the action button on the right shifter.



## HOW TO USE THE SHIFTERS

The shifters on your AtomX control specific actions;

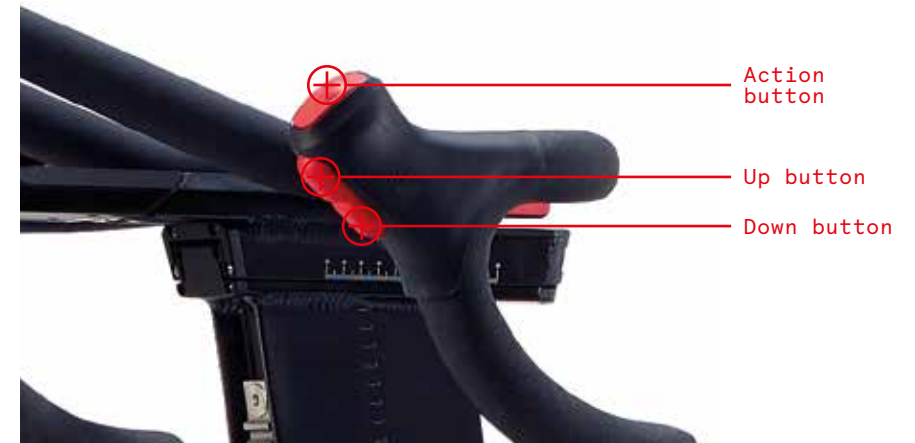

### The shifter on the right:

- Action Button\* – Mode selection
- Up button:
  - Click: Increase Gear or Target Watts
  - Hold: Increase Gear or Target Watts + multiple changes
- Down button
  - Click: Decrease Gear or Target Watts
  - Hold: Decrease Gear or Target Watts + multiple changes

### The shifter on the left:

- Action Button\*: + 1 Lap (for Just Ride and Climb mode only)
- Up button:
  - Click: Scroll to next view
- Down button
  - Click – Scroll to previous view

**\*TIP: When pressing the action button, push the button in the middle of the red part of the shifter.**

## SET UP

The Wattbike AtomX can accommodate any rider through our unique real ride setup. Use the corresponding adjustment levers to manipulate the saddle and handlebar positions to get the right fit.

### STEP 1: SETTING THE SADDLE HEIGHT



### STEP 2: SETTING THE SADDLE HORIZONTAL POSITION



### STEP 3: SETTING THE HANDLEBAR POSITION



# 05 PERFORMANCE TOUCHSCREEN

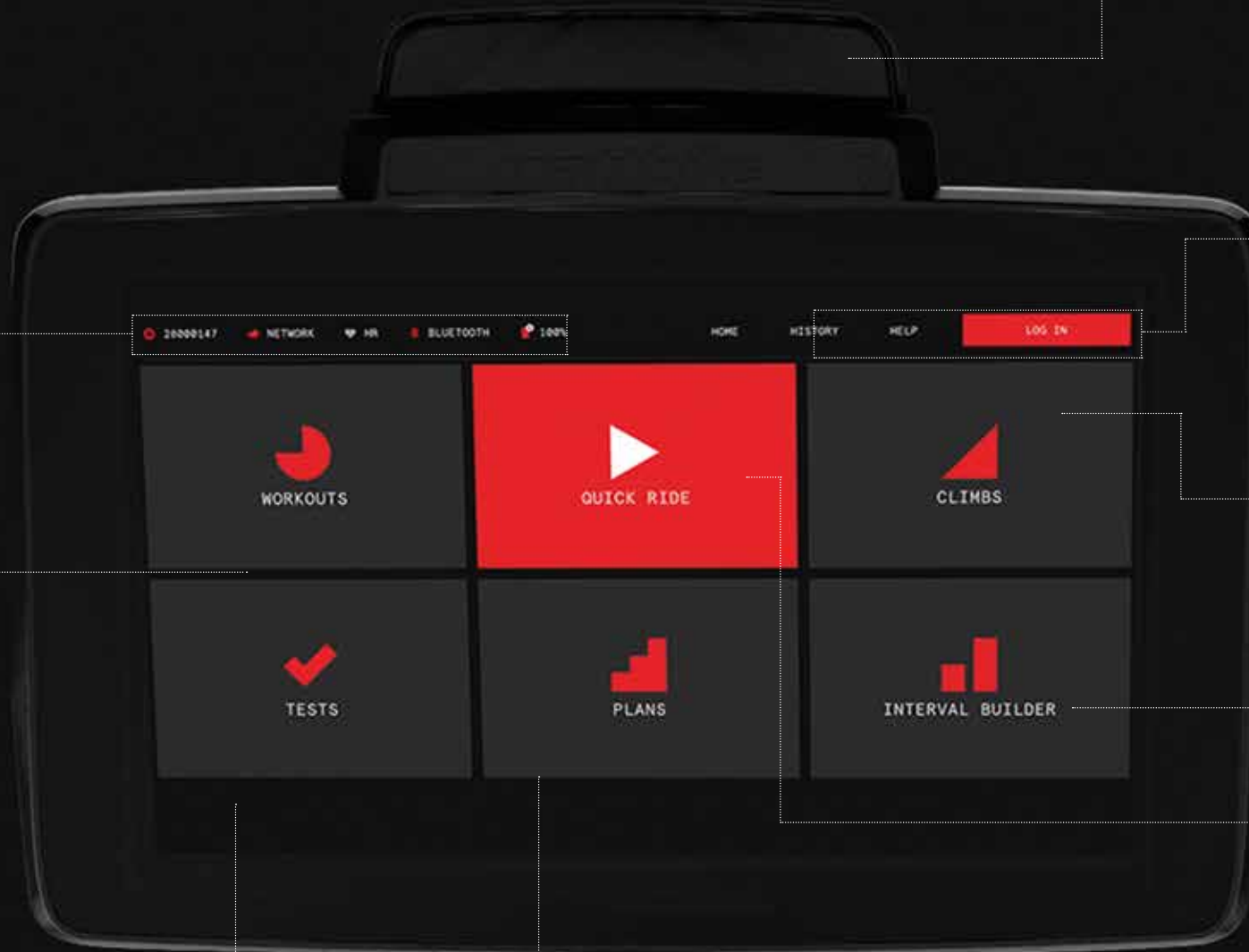

## SERIAL NUMBER

Use this ID when connecting third-party apps. Click for bike information and advanced options.

## NETWORK STATUS

For automatic updates and a fully connected user experience, ensure you are connected to a network.

## HR

Train efficiently by connecting a heart rate monitor - simply tap the heart rate icon to do so.

## BLUETOOTH

See how to connect to Wattbike Hub and third-party apps.

## WORKOUTS

Access the world's best workouts. Categories include Endurance, Speed, HIIT and Cycling Simulations.

## INTERVAL BUILDER

Allow your clients and members to build their own custom interval workouts with this tool.

## TESTS

Track, benchmark and analyse performance with Wattbike's accurate tests.

## DEVICE HOLDER

## HOME

Touch 'HOME' to return to the home screen.

## HISTORY

Access session history, save workouts to your Wattbike Hub account, and keep track of usage here.

## HELP

Access FAQs and tips regarding your Wattbike AtomX.

## LOG IN

Log in to a Wattbike Hub account for a more personalised experience and to save sessions.

## CLIMBS

Take on bucket list climbs with automated gradient mapping

## POWER BUTTON

## QUICK RIDE

Don't want to follow a specific workout? Start an open session here.

## PLANS

Bring your Wattbike plan with you. Learn more here.

## PORTS

HDMI port, 1 micro USB for maintenance and diagnostics, USB port for external device charging, audio jack.

## 06 GET CONNECTED

### LINKING UP A HEART RATE SENSOR

The Wattbike is compatible with all popular HR belts, and can be synced up either before or during a session. Simply tap the HR icon at the top of the screen to link up at any time.

### CONNECTING TO THIRD PARTY APPS

Your AtomX can connect to third party training apps such as The Sufferfest, Zwift and TrainerRoad through your phone or tablet. To do this, follow the below steps:

1. Enable Bluetooth or ANT+ on your device (phone, tablet or computer)
2. Open your preferred training app and navigate to the point of connecting your indoor trainer
3. Select the ID shown in the top left corner of the Performance Touchscreen, for example: 'WattbikeAtomX12345' or '12345'
4. The Touchscreen will switch to a Quick Ride screen and the bike will be controlled by your chosen third-party app through your smart device

You can connect to any training apps which support Bluetooth or ANT+\*.



\*To use third party apps, a mobile device needs to be connected to the Wattbike via Bluetooth or ANT+, and personal subscriptions to the app are also required.

### CONNECTING TO A NETWORK

1. Swipe up from the bottom of the screen



2. Select the dot at the bottom of the screen





- 3 Select the 'Settings' icon then 'Wi-Fi settings'



- 4 Select and connect to your network

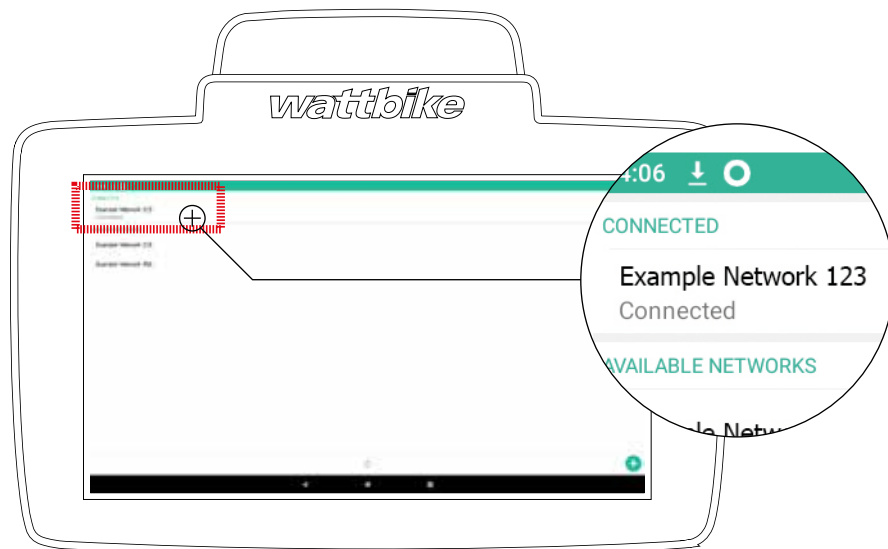

## 07 MAINTENANCE

### AFTER EACH SESSION

To ensure your AtomX stays in good condition use a clean, soft cloth and non-abrasive liquid cleaner after each session to remove all sweat, dust, dirt and other substances.

### REGULAR MAINTENANCE

Where necessary:

- Vacuum the floor under and around the AtomX to prevent dust ingress
- Inspect the saddle and handlebar stem adjustment levers. Tighten and grease as necessary
- Check that the pedals are secure and fit for use. Replace straps, cages and pedals if necessary
- Ensure that no sweat/liquid is pooling on the metalwork or covers

### ADDITIONAL RESOURCES

For more information and full set up guides, visit the support section of [wattbike.com](http://wattbike.com)





